

4

3

2

1

NOTES: UNLESS OTHERWISE SPECIFIED

- 1. A (REF) DIMENSION IS FOR INFORMATION PURPOSES ONLY AND NO TOLERANCE IS IMPLIED.
- 2. CABLE NOT INCLUDED

| REVISION HISTORY | | | |
|------------------|------------------------------------|----------|----------|
| REV | DESCRIPTION | DATE | APPROVED |
| C | OUTLINE DIMENSIONAL DRAWING UPDATE | 8/7/2017 | CV |

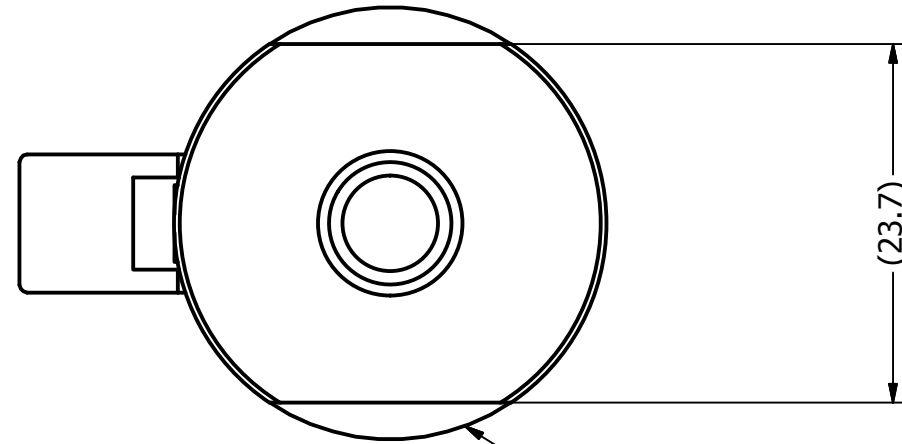

(23.7)

1 1/8-18 UNEF
M-MOUNT INTERFACE

3/8-24 UNF STUD

FLANGE NUT

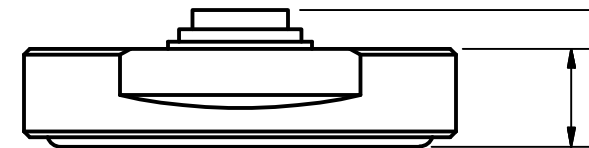

(6.5)

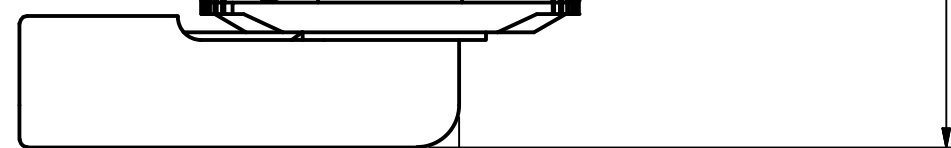

(29.1)

(31.0)

| | | | | | | | |
|---|--|---|--|--|--|--|--|
| SUPPLIER PRINT ACCEPTANCE: <input type="checkbox"/> Accept drawing/specification: No changes needed: <input type="checkbox"/> This part is RoHS compliant <input type="checkbox"/> This part is REACH compliant <input type="checkbox"/> Accept drawing/specification. Notes/Mark-ups added <input type="checkbox"/> Cannot accept drawing/spec. Notes/Mark-ups added Supplier Projected Outgoing Quality: SIGMA LEVEL : _____ or PPM: _____ Signature _____ Date: _____ | | UNLESS OTHERWISE SPECIFIED DIMENSIONS ARE IN MILLIMETERS FOR TOLERANCES NOT SPECIFIED USE: [X mm ± 3 mm] [X.X mm ± .3 mm] [X.XX mm ± .13 mm] ANGULAR ± 1° THIRD ANGLE PROJECTION | | DRAWN: CV DATE: 8/7/2017 CHECKED: _____ DATE: _____ MATERIAL: _____ FINISH: _____ | | PCTEL, INC. 471 BRIGHTON DRIVE BLOOMINGDALE, IL 60108 PH. 630-372-6800 FAX. 630-372-8077 | |
| | | | | DESCRIPTION: 3/8 ADJ TKNS MT., NO CABLE, TO 1/2 | | | |
| | | | | DRAWING NO. ODD_BMATM338 | | | |
| | | SIZE: B | | SCALE: 2:1 | | SHEET: 1 OF 1 | |

4

3

4

2

1

4

3

2

1

NOTES: UNLESS OTHERWISE SPECIFIED

1. A (REF) DIMENSION IS FOR INFORMATION PURPOSES ONLY AND NO TOLERANCE IS IMPLIED.

| REVISION HISTORY | | | |
|------------------|------------------------------------|----------|----------|
| REV | DESCRIPTION | DATE | APPROVED |
| A | OUTLINE DIMENSIONAL DRAWING UPDATE | 8/7/2017 | CV |

| | | | | |
|---|---|--|--|---|
| SUPPLIER PRINT ACCEPTANCE: <input type="checkbox"/> Accept drawing/specification: No changes needed: <input type="checkbox"/> This part is RoHS compliant <input type="checkbox"/> This part is REACH compliant <input type="checkbox"/> Accept drawing/specification. Notes/Mark-ups added <input type="checkbox"/> Cannot accept drawing/spec. Notes/Mark-ups added Supplier Projected Outgoing Quality: SIGMA LEVEL : _____ or PPM: _____ Signature _____ Date: _____ | UNLESS OTHERWISE SPECIFIED DIMENSIONS ARE IN MILLIMETERS FOR TOLERANCES NOT SPECIFIED USE: [X mm ± 3 mm] [X.X mm ± .3 mm] [X.XX mm ± .13 mm] ANGULAR ± 1° | DRAWN CV CHECKED DATE 8/7/2017 | PCTEL, INC. 471 BRIGHTON DRIVE BLOOMINGDALE, IL 60108 PH. 630-372-6800 FAX. 630-372-8077 | |
| | THIRD ANGLE PROJECTION | MATERIAL: FINISH: | | DESCRIPTION 3/8 ADJ MNT TO 1/2", RG58, NO CONN. |
| PCTEL PROPRIETARY DATA THE INFORMATION AND/OR DRAWINGS CONTAINED IN THIS DOCUMENT IS CONFIDENTIAL AND PROPRIETARY TO PCTEL, INC. AND MAY NOT BE USED, REPRODUCED, IN WHOLE OR IN PART, OR MODIFIED IN ANY WAY WITHOUT THE EXPRESS WRITTEN PERMISSION OF AN AUTHORIZED REPRESENTATIVE OF PCTEL, INC. | | DRAWING NO. ODD_BMATM3-NC | | |
| | | SIZE B | SCALE 1.5:1 | SHEET 1 OF 1 |

4

3

2

1

NOTES: UNLESS OTHERWISE SPECIFIED

1. DIMENSIONS IN PARENTHESIS ARE FOR REFERENCE ONLY AND NO TOLERANCE IS IMPLIED.

| REVISION HISTORY | | | |
|------------------|--------------------------------------|---------|----------|
| REV | DESCRIPTION | DATE | APPROVED |
| A1 | OUTLINE DIMENSIONAL DRAWING RELEASED | 01SEP11 | JD |

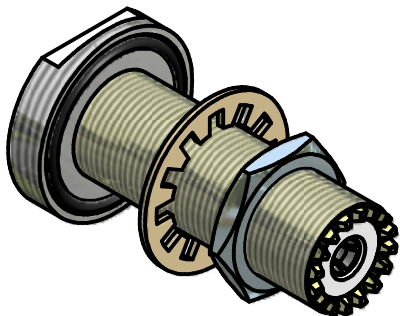
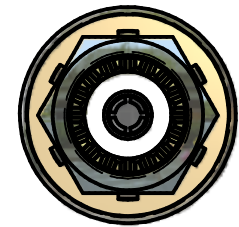
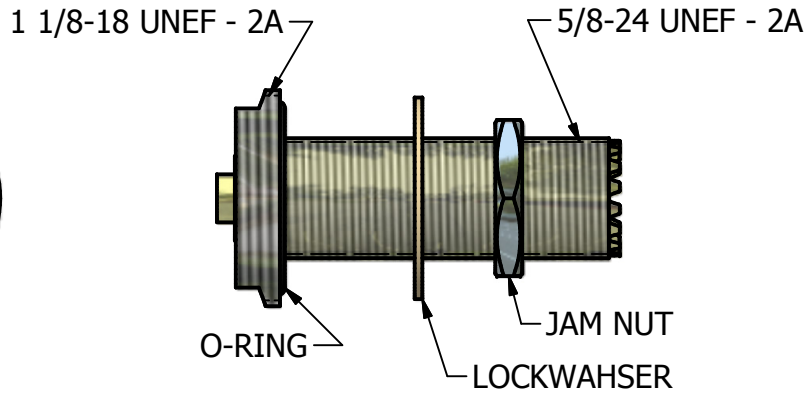
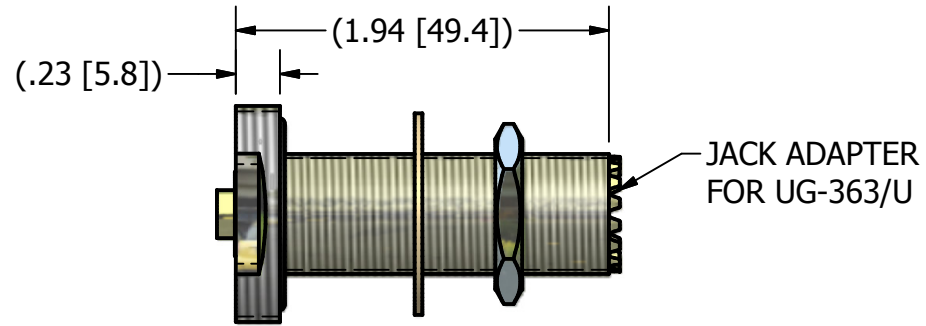

| | | | |
|--|---|---|--|
| <p>UNLESS OTHERWISE SPECIFIED DIMENSIONS ARE IN INCHES [DIMENSIONS ARE IN mm]</p> <p>FOR TOLERANCES NOT SPECIFIED USE: X.X in ± .1 in, X.XX in ± .01 in, X.XXX in ± .005 in [X mm ± 3 mm], [X.X mm ± .3 mm], [X.XX mm ± .13 mm] ANGULAR ± 1°, FRACTIONAL ± 1/64</p> <p>THIRD ANGLE PROJECTION</p>  <p>PROPRIETARY DATA</p> <p>THE INFORMATION CONTAINED IN THIS DOCUMENT IS OF A PROPRIETARY NATURE. IT MAY NOT BE USED OR REPRODUCED WITHOUT EXPRESS WRITTEN PERMISSION OF PCTEL INC., BLOOMINGDALE, IL 60108</p> | <p>DRAWN: IP</p> <p>CHECKED:</p> <p>APPROVED:</p> <p>MATERIAL: SEE COMPONENT PRINTS</p> <p>FINISH: SEE COMPONENT PRINTS</p> | <p>DATE: 9/1/2011</p> <p>DATE:</p> <p>DATE:</p> | <p>PCTEL, INC. BROADBAND TECHNOLOGY GROUP ANTENNA PRODUCTS 471 BRIGHTON DRIVE BLOOMINGDALE, IL 60108 PH. 630-372-6800 FAX. 630-372-8077</p> <p>PCTEL <i>simplifying mobility</i></p> |
| | DESCRIPTION: THICK PLATE MOUNT | | |
| | DRAWING NO.: ODD_MTPM | | |
| | SIZE: A | SCALE: 1:1 | |

| REVISION HISTORY | | | |
|------------------|---|------------|----------|
| REV | DESCRIPTION | DATE | APPROVED |
| 1 | VANDAL PROOF MOUNT, HIGH PERFORMANCE, M TO NF | 09/06/2016 | CE |

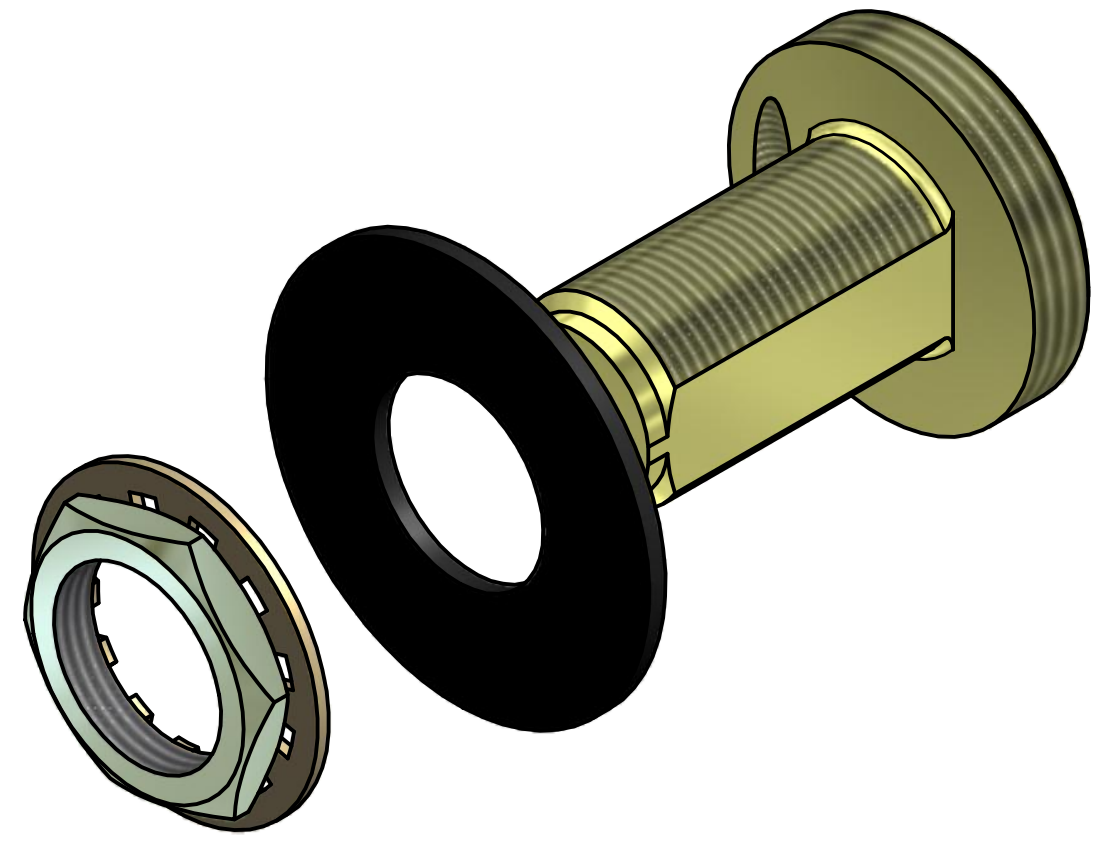
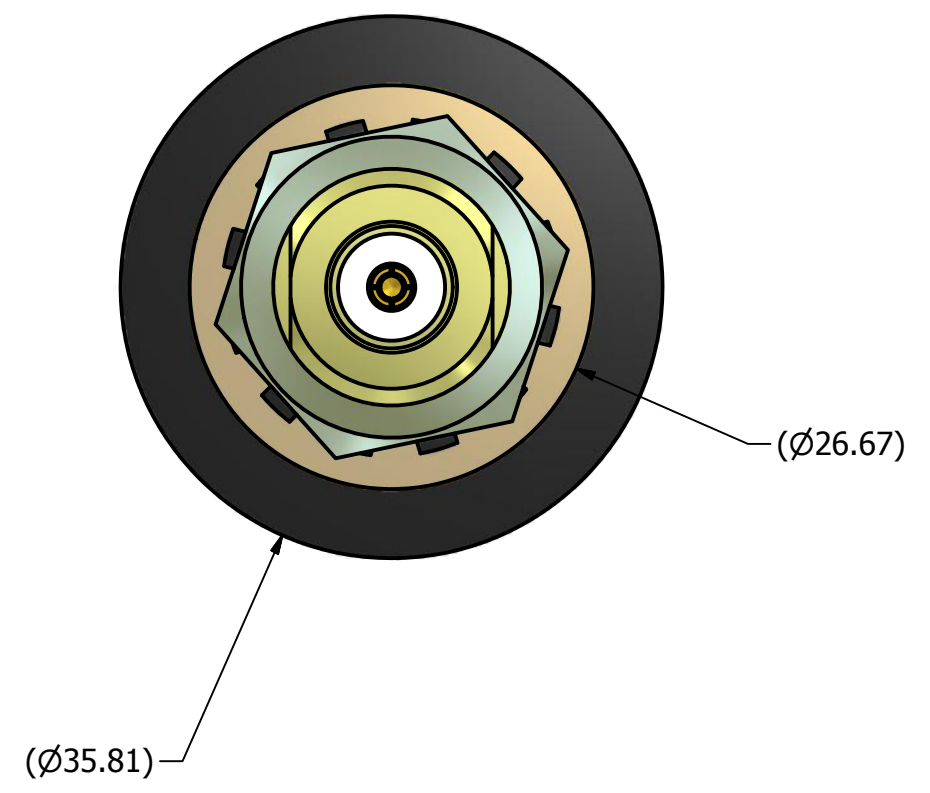
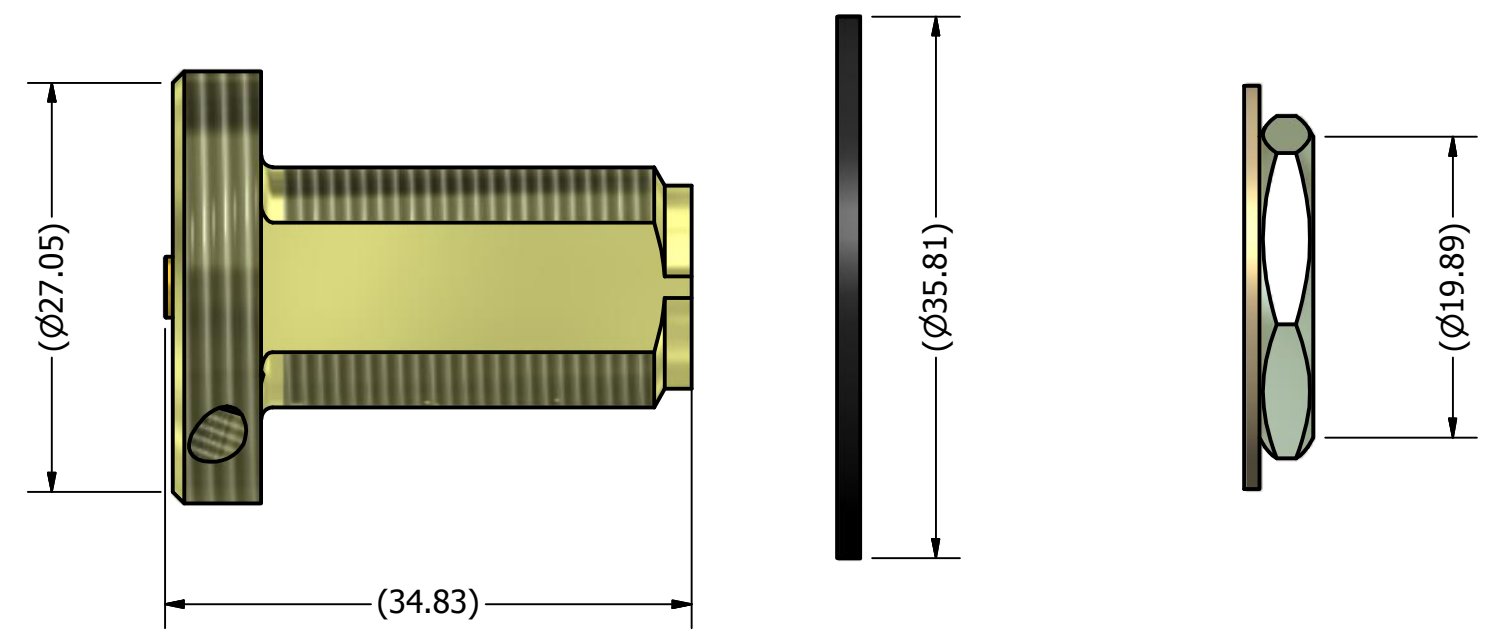

NOTES: UNLESS OTHERWISE SPECIFIED
 1. A (REF) DIMENSION IS FOR INFORMATION PURPOSES ONLY AND NO TOLERANCE IS IMPLIED.

| | | | |
|---|---|--|--|
| SUPPLIER PRINT ACCEPTANCE: <input type="checkbox"/> Accept drawing/specification: No changes needed: <input type="checkbox"/> This part is RoHS compliant <input type="checkbox"/> This part is REACH compliant <input type="checkbox"/> Accept drawing/specification. Notes/Mark-ups added <input type="checkbox"/> Cannot accept drawing/spec. Notes/Mark-ups added Supplier Projected Outgoing Quality: SIGMA LEVEL : _____ or PPM: _____ Signature _____ Date: _____ | UNLESS OTHERWISE SPECIFIED DIMENSIONS ARE IN MILLIMETERS FOR TOLERANCES NOT SPECIFIED USE: [X mm ± 3 mm] [X.X mm ± .3 mm] [X.XX mm ± .13 mm] ANGULAR ± 1° | DRAWN: CE DATE: 9/6/2016 CHECKED: IP DATE: 9/6/2016 MATERIAL: SEE COMPONENT PRINTS FINISH: SEE COMPONENT PRINTS | PCTEL, INC. 471 BRIGHTON DRIVE BLOOMINGDALE, IL 60108 PH. 630-372-6800 FAX. 630-372-8077 |
| | THIRD ANGLE PROJECTION | PCTEL PROPRIETARY DATA THE INFORMATION AND/OR DRAWINGS CONTAINED IN THIS DOCUMENT IS CONFIDENTIAL AND PROPRIETARY TO PCTEL, INC. AND MAY NOT BE USED, REPRODUCED, IN WHOLE OR IN PART, OR MODIFIED IN ANY WAY WITHOUT THE EXPRESS WRITTEN PERMISSION OF AN AUTHORIZED REPRESENTATIVE OF PCTEL, INC. | |

4

3

2

1

NOTES: UNLESS OTHERWISE SPECIFIED

1. INTERPRET DRAWING PER ANSI/ASME Y14.5
2. MATERIAL: SEE INDIVIDUAL COMPONENT PRINTS.
3. FINISH: SEE INDIVIDUAL COMPONENT PRINTS.
4. ALL MATERIALS SHALL BE ROHS COMPLIANT.
- 5.A (REF) DIMENSION IS FOR INFORMATION PURPOSES ONLY AND NO TOLERANCE IS IMPLIED.

| REVISION HISTORY | | | |
|------------------|----------------------------|----------|----------|
| REV | DESCRIPTION | DATE | APPROVED |
| A1 | EDITED CABLE NOTE (C16860) | 06/11/15 | ZV |

BRASS BUSHING
ALBALOY PLATING

SET SCREW LOCKS ON TO ANTENNA MAKING
THE ASSEMBLY VANDAL PROOF

1 1/8-7 UNC-2A THREADS

5/8-24 JAM NUT

CABLE ASSEMBLY WITH
FEMALE SMA CONNECTOR
SHOWN FOR ILLUSTRATION PURPOSE
ONLY. NOT SUPPLIED WITH THE MOUNT.

| | | | |
|---|--|---|---|
| SUPPLIER PRINT ACCEPTANCE: <input type="checkbox"/> Accept drawing/specification: No changes needed: <input type="checkbox"/> This part is RoHS compliant <input type="checkbox"/> This part is REACH compliant <input type="checkbox"/> Accept drawing/specification. Notes/Mark-ups added <input type="checkbox"/> Cannot accept drawing/spec. Notes/Mark-ups added Supplier Projected Outgoing Quality: SIGMA LEVEL : _____ or PPM: _____ Signature _____ Date: _____ | UNLESS OTHERWISE SPECIFIED DUAL DIMENSIONING XX.Xin [XX.Xmm] FOR TOLERANCES NOT SPECIFIED USE: X.X in ± .1 in, X.XX in ± .01 in, X.XXX in ± .005 in [X mm ± 3 mm], [X.X mm ± .3 mm], [X.XX mm ± .13 mm] ANGULAR ± 1°, FRACTIONAL ± 1/64 | DRAWN ZV DATE 12/9/2013 CHECKED _____ DATE _____ | <div style="display: flex; align-items: center;"> <div> <p>PCTEL, INC. 471 BRIGHTON DRIVE BLOOMINGDALE, IL 60108 PH. 630-372-6800 FAX. 630-372-8077</p> </div> </div> |
| THIRD ANGLE PROJECTION | MATERIAL: SEE NOTE 2 FINISH: SEE NOTE 3 | DESCRIPTION VANDAL PROOF MOUNT, M TO NF | |
| PCTEL PROPRIETARY DATA THE INFORMATION AND/OR DRAWINGS CONTAINED IN THIS DOCUMENT IS CONFIDENTIAL AND PROPRIETARY TO PCTEL, INC. AND MAY NOT BE USED, REPRODUCED, IN WHOLE OR IN PART, OR MODIFIED IN ANY WAY WITHOUT THE EXPRESS WRITTEN PERMISSION OF AN AUTHORIZED REPRESENTATIVE OF PCTEL, INC. | | DRAWING NO. ODD-MMF-VP SIZE B SCALE 1:1 SHEET 1 OF 1 | |

4

3

2

1